



Raychem

DESIGN GUIDELINES
XL-TRACE LSZH SELF-REGULATING HEATING CABLES
FOR PIPE FREEZE PROTECTION SYSTEMS

 @PentairThermal

THERMAL MANAGEMENT |

WWW.PENTAIRTHERMAL.COM

PIPE FREEZE PROTECTION

SYSTEM OVERVIEW

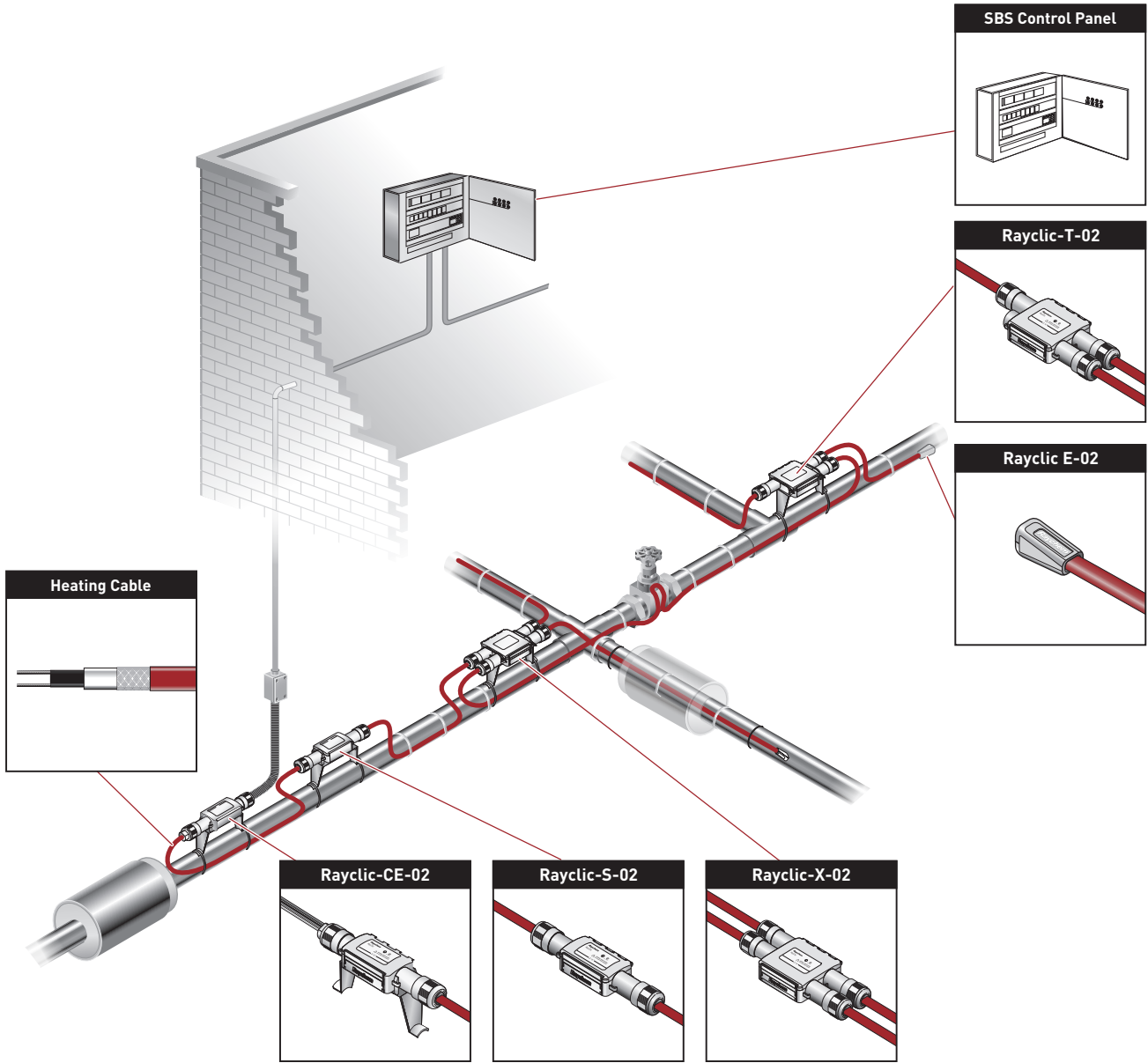

This is a sample overview of pipe freeze protection applications for illustration purposes only, with typical layouts shown on the following pages.

Please contact your local representative for any further design support.

PIPE FREEZE PROTECTION

SINGLE CIRCUIT

Cold Water Services

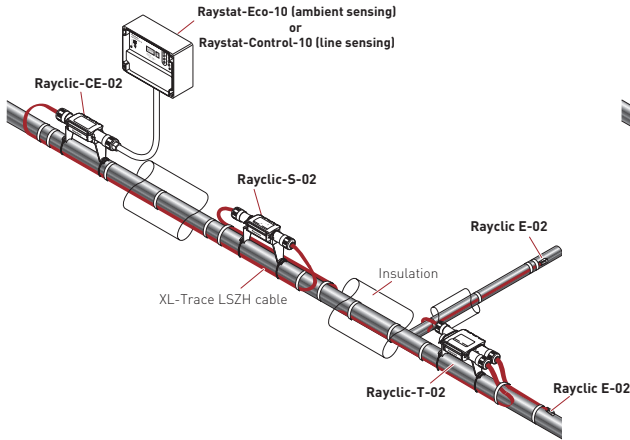

Low Pressure Hot Water Services (LPHW)

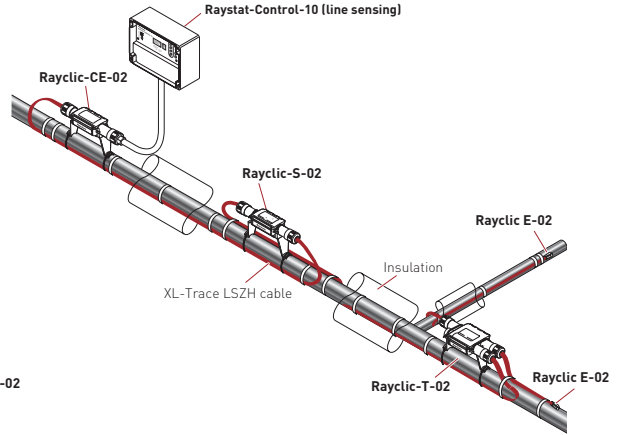

XL-Trace LSZH cable		
10 W/m @ 5°C	15 W/m @ 5°C	26 W/m @ 5°C

XL-Trace LSZH cable
31 W/m @ 5°C

MULTIPLE CIRCUIT

Cold Water + LPHW Services

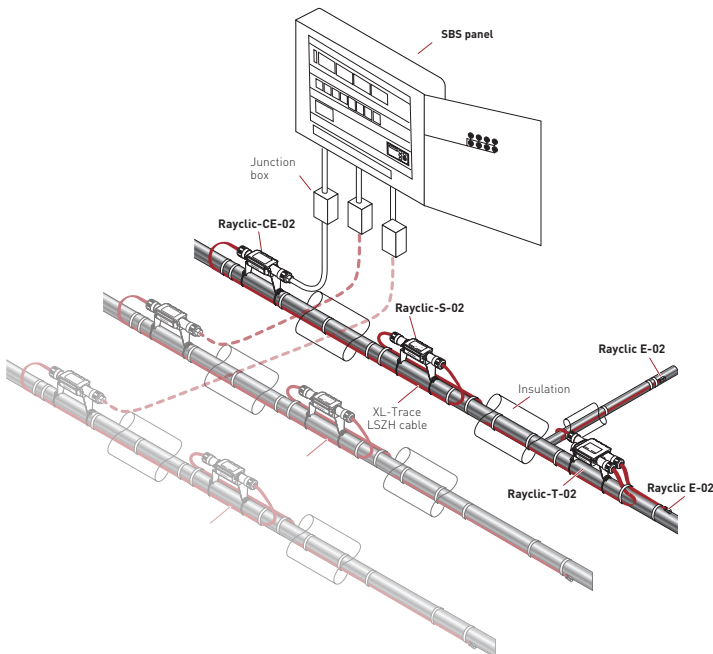

Fire Sprinkler Lines
(with redundant heat tracing according to EN12845 / VDE)

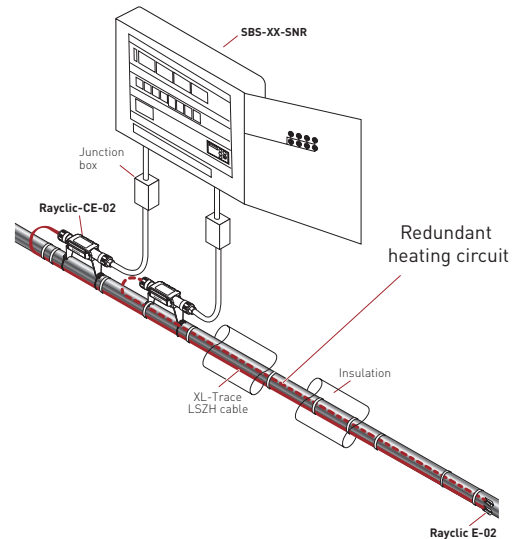

XL-Trace LSZH cable			
for cold water			for LPHW services
10 W/m @ 5°C	15 W/m @ 5°C	26 W/m @ 5°C	31 W/m @ 5°C

XL-Trace LSZH cable		
for fire sprinkler lines		
10 W/m @ 5°C	15 W/m @ 5°C	26 W/m @ 5°C

PIPE FREEZE PROTECTION

MULTIPLE CIRCUITS (ABOVE 12) OR MULTIPLE APPLICATIONS

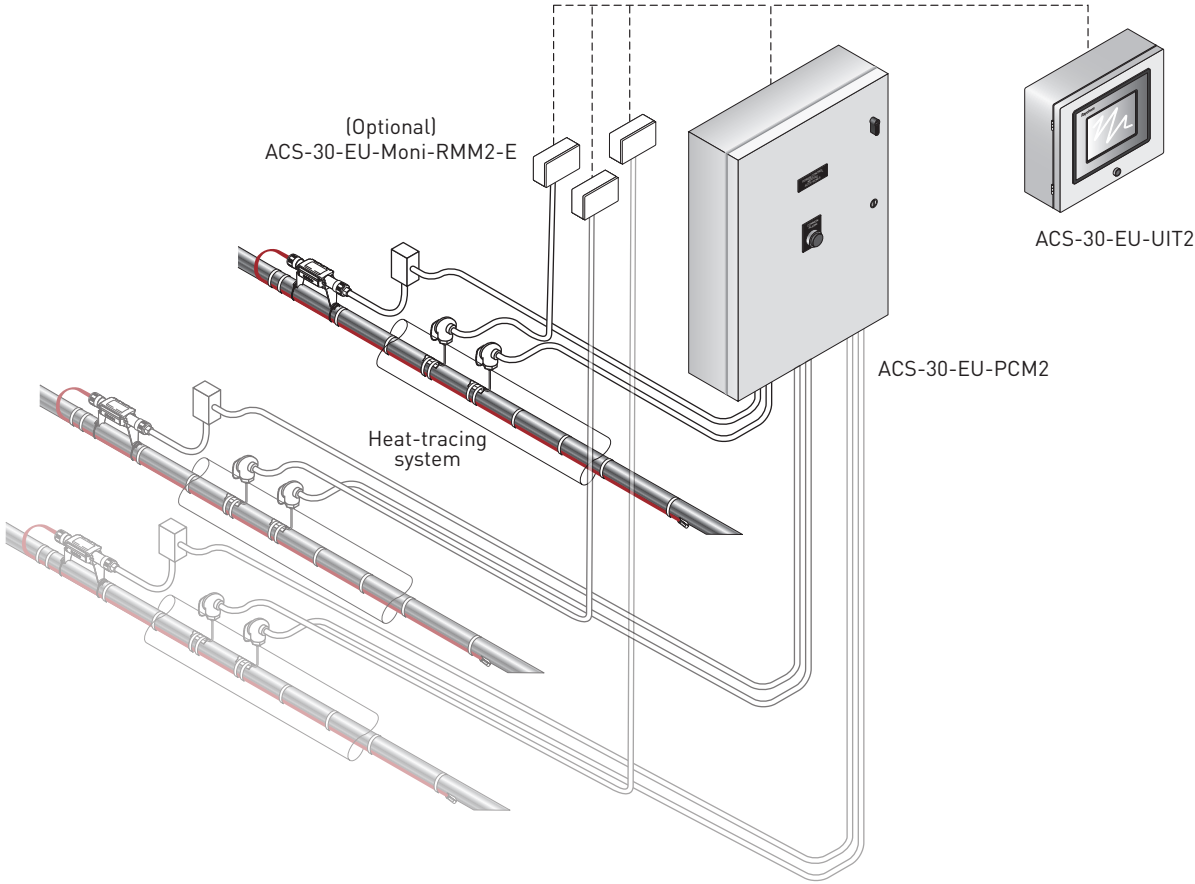

XL-Trace LSZH cable			
for cold water			for LPHW services
10 W/m @ 5°C	15 W/m @ 5°C	26 W/m @ 5°C	31 W/m @ 5°C

FLOW MAINTENANCE (GREASE LINE)

SYSTEM OVERVIEW

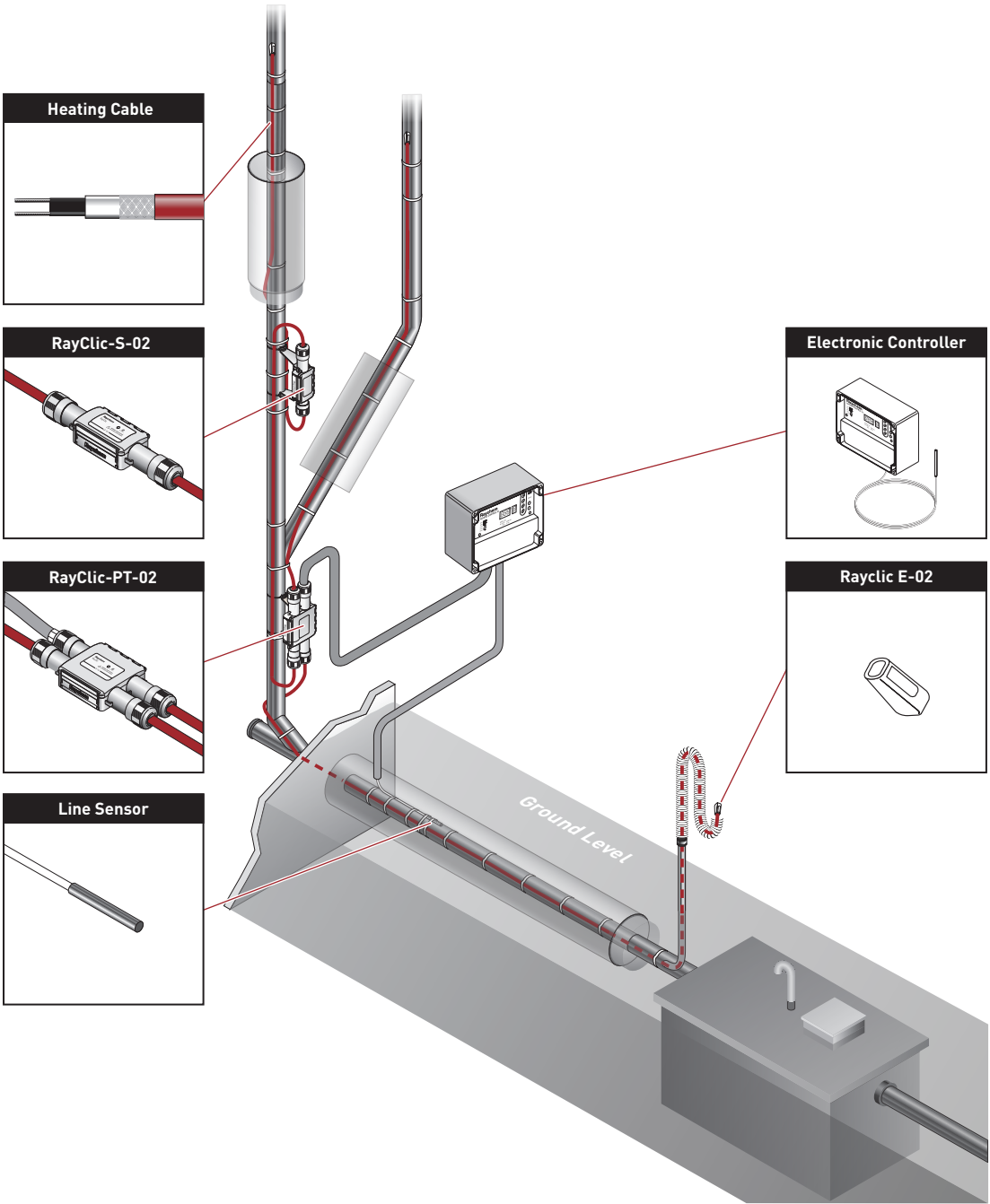

This is a sample overview for flow maintenance of greasy waste pipes for illustration purposes only, with typical layouts shown on the following page.

Please contact your local representative for any further design support.

FLOW MAINTENANCE (GREASE LINE)

SINGLE CIRCUIT

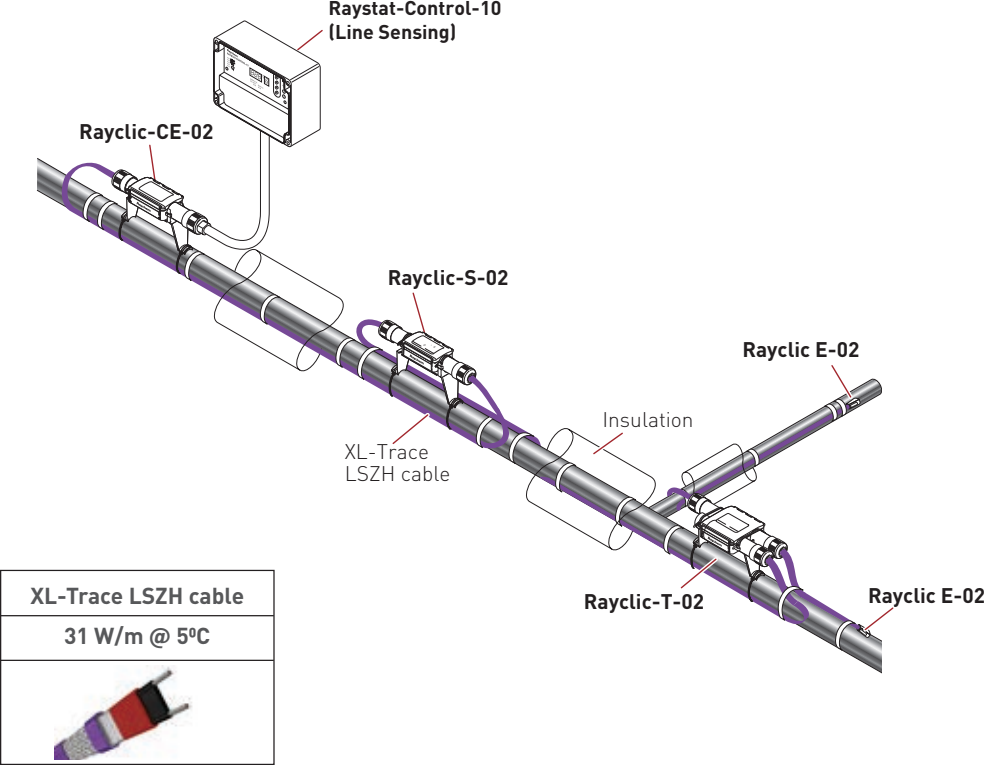

MULTIPLE CIRCUIT (UP TO 12)

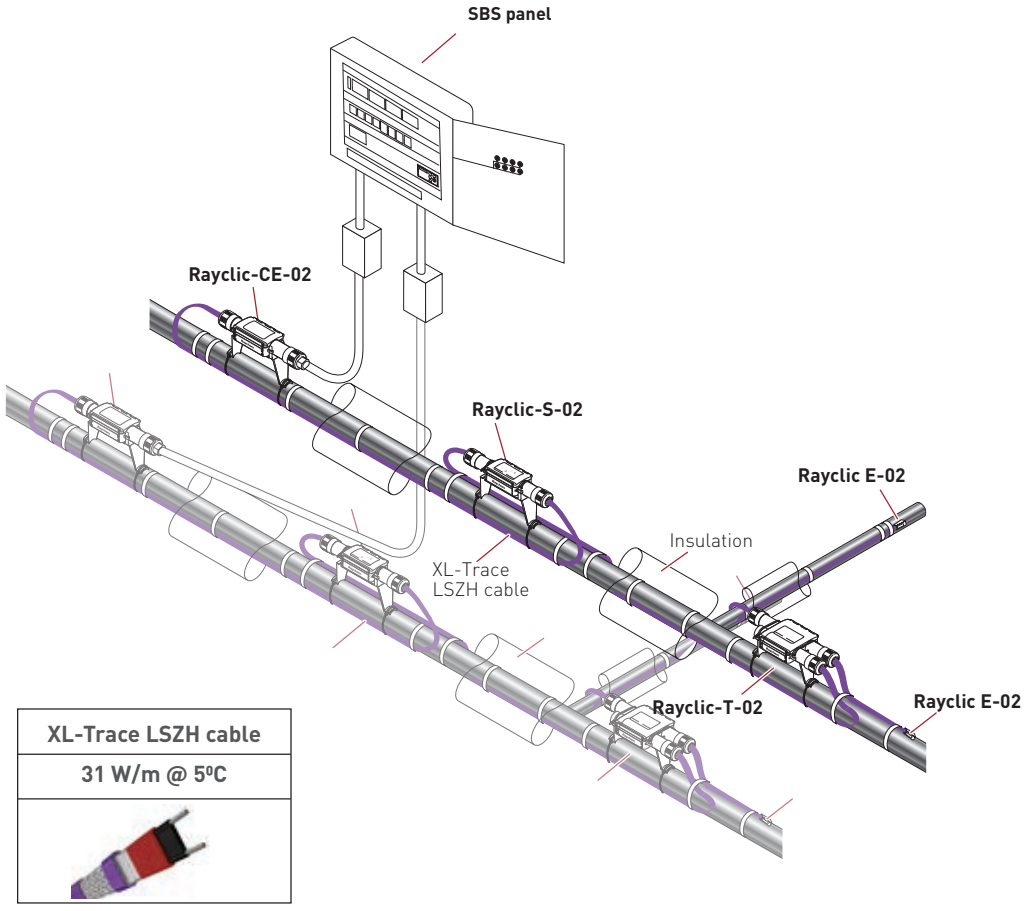

HEATING CABLE CONSTRUCTION

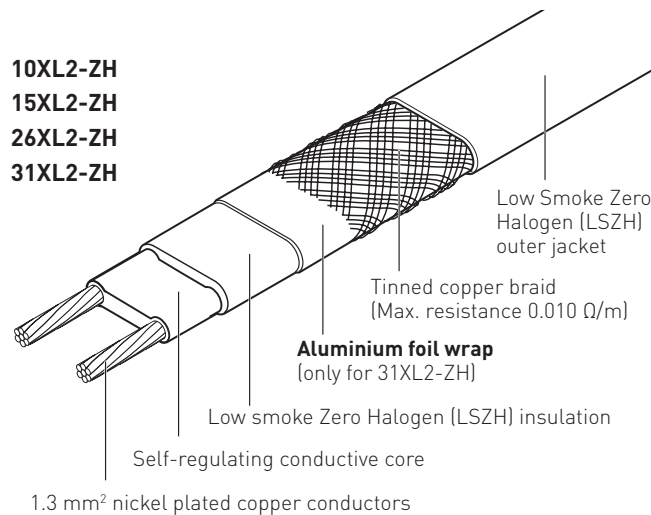

HEATING CABLE LENGTH

Pipe Freeze Protection at Minimum Ambient Temp -20°C

For more accurate product selection and installation specific data, please use TraceCalc Pro for Buildings

Pipe diameter (mm)													
Insulation thicknesses (mm)	15	22	28	35	42	54	67	76	108	125	150	200	
10	10XL2-ZH	15XL2-ZH	15XL2-ZH	26XL2-ZH	26XL2-ZH	26XL2-ZH	26XL2-ZH	31XL2-ZH	31XL2-ZH	31XL2-ZH	31XL2-ZH	31XL2-ZH	31XL2-ZH
15	10XL2-ZH	10XL2-ZH	10XL2-ZH	10XL2-ZH	15XL2-ZH	15XL2-ZH	26XL2-ZH	26XL2-ZH	26XL2-ZH	31XL2-ZH	31XL2-ZH	31XL2-ZH	31XL2-ZH
20	10XL2-ZH	10XL2-ZH	10XL2-ZH	10XL2-ZH	10XL2-ZH	15XL2-ZH	15XL2-ZH	26XL2-ZH	26XL2-ZH	31XL2-ZH	31XL2-ZH	31XL2-ZH	31XL2-ZH
25	10XL2-ZH	10XL2-ZH	10XL2-ZH	10XL2-ZH	10XL2-ZH	10XL2-ZH	15XL2-ZH	15XL2-ZH	26XL2-ZH	26XL2-ZH	26XL2-ZH	26XL2-ZH	31XL2-ZH
30	10XL2-ZH	10XL2-ZH	10XL2-ZH	10XL2-ZH	10XL2-ZH	10XL2-ZH	10XL2-ZH	15XL2-ZH	15XL2-ZH	26XL2-ZH	26XL2-ZH	26XL2-ZH	26XL2-ZH
40	10XL2-ZH	10XL2-ZH	10XL2-ZH	10XL2-ZH	10XL2-ZH	10XL2-ZH	10XL2-ZH	10XL2-ZH	15XL2-ZH	15XL2-ZH	26XL2-ZH	26XL2-ZH	26XL2-ZH
50	10XL2-ZH	10XL2-ZH	10XL2-ZH	10XL2-ZH	10XL2-ZH	10XL2-ZH	10XL2-ZH	10XL2-ZH	10XL2-ZH	15XL2-ZH	26XL2-ZH	26XL2-ZH	26XL2-ZH

Pipe freeze protection cables XL-Trace LSZH are suitable for any pipe material (copper, threaded pipes, stainless steel pipes, plastic pipes and composite metal pipes) without restriction.

For plastic pipes, please use aluminium adhesive tape ATE-180. The pipe freeze protection cable should be covered along its entire length. Heat insulation $\lambda = 0.035 \text{ W/(m.K)}$ or better.

Note: For insulation types containing solvents and/or bitumen coating, use the 31XL2-ZH product.

Application

Pipe freeze protection of pipework. Maximum operating temperature 65°C.

10XL2-ZH	10W/m @ 5°C.
15XL2-ZH	15W/m @ 5°C.
26XL2-ZH	26W/m @ 5°C.

Pipe freeze protection and temperature maintenance. Maximum operating temperature 85°C.

31XL2-ZH	31W/m @ 5°C.
----------	--------------

40°C temperature maintenance on pipelines for fatty waste water

Pipe diameter (mm)								
Insulation Thickness	42	54	67	76	108	125	150	200
30 mm	31XL							
40 mm	31XL	31XL						
50 mm	31XL	31XL	31XL					
60 mm	31XL	31XL	31XL	31XL				
80 mm	31XL	31XL	31XL	31XL	31XL			
100 mm	31XL	31XL	31XL	31XL	31XL	31XL		
125 mm	31XL	31XL	31XL	31XL	31XL	31XL	31XL	
150 mm	31XL	31XL	31XL	31XL	31XL	31XL	31XL	31XL

Min. ambient temperature -10°C . Heat insulation $\lambda = 0.035 \text{ W}/(\text{m}\cdot\text{K})$ or better.

Cable type 31XL2-ZH should only be used in conjunction with pipework with a minimum continuous temperature resistance of 90°C . A line-sensing control thermostat (type AT-TS-14, RAYSTAT-CONTROL-10 or RAYSTAT-CONTROL-11-DIN) must be used on plastic pipework (setting approx. 40°C).

CABLE LENGTH

The heating cable should be installed in a straight line on the pipework. Cable loops instead of T-connections can be made on short dead legs.

(up to approx. 3 m)

+ approx. 0.3 m per connection

+ approx. 1.0 m per T-connection

+ approx. 1.2 m per 4-way connection

Additional cable required for increased heat sinks at valves from 2" and for uninsulated pipe supports (approx. 1 m)

= required heating cable length

ELECTRICAL PROTECTION

- The total length of heating cable determines the number and size of the fuses
- Residual current device (rcd) : 30 mA required, max. 500 m heating cable per rcd
- Installation according to local regulations
- The power connections must be carried out by an approved electrical installer
- Use C type circuit-breakers

XL-Trace Maximum Circuit Lengths

10XL2-ZH (240 Vac)	Circuit Breaker (C Type characteristic CB Size)					
Switch-On Temperature [°C]	4	6	10	13	16	20
-20	25	40	75	100	140	180
-10	30	50	90	130	170	190
-5	40	60	110	150	190	200
0	45	70	125	170	210	210
5	50	80	140	195	215	215

15XL2-ZH (240 Vac)	Circuit Breaker (C Type characteristic CB Size)					
Switch-On Temperature [°C]	4	6	10	13	16	20
-20	10	25	50	70	90	120
-10	12	30	60	85	110	145
-5	25	40	70	95	120	155
0	29	45	80	110	135	160
5	35	50	90	120	155	160

XL-Trace Maximum Circuit Lengths

26XL2-ZH (240 Vac)	Circuit Breaker (C Type characteristic CB Size)					
Switch-On Temperature (°C)	4	6	10	13	16	20
-20	12	12	40	55	80	110
-10	12	25	50	70	100	125
-5	12	30	55	85	110	130
0	12	35	70	100	125	135
5	20	40	80	110	135	135

31XL2-ZH (240 Vac)	Circuit Breaker (C Type characteristic CB Size)					
Switch-On Temperature (°C)	4	6	10	13	16	20
-20	15	25	50	65	80	105
-10	20	30	55	75	90	115
-5	22	35	59	79	100	118
0	24	38	64	85	105	118
5	26	40	67	88	110	118

TESTING OF THE INSTALLATION

For testing and commissioning of the XL-Trace LSZH heater cables, please consult the installation and commissioning manual, reference CDE1547.

CONTROL PANELS

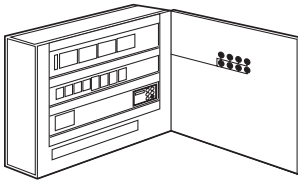

Steel plate housing, wall-mounted version, equipped with mains power switch, RCD/CB combination, inlet and outlet terminals. Completely assembled, turnkey condition wired and inspected cable guides in base of housing. The control panel contains a HWAT-ECO temperature control.

SBS-03-SV

Switch cabinet for 1 to 3 heating circuits.

- PCN: 355825-000

SBS-06-SV

Control panel for 4 to 6 heating circuits.

- PCN: 778308-000

SBS-09-SV

Control panel for 7 to 9 heating circuits.

- PCN: 767989-000

SBS-12-SV

Control panel for 10 to 12 heating circuits.

- PCN: 1244-000025

Cabinet type			SBS-03-SV	SBS-06-SV	SBS-09-SV	SBS-12-SV	
Max. number of heating circuits			3	6	9	12	
Enclosure version			Wall version	Wall version	Wall version	Wall version	
Dimensions	Width	mm	400	400	400	400	
	Height	mm	600	600	600	600	
	Depth	mm	210	210	210	210	
Weight	approx.	kg	32	32	32	32	
Maximum Nominal Current			A	25	32	63	80

When using standard control panels for pipe freeze protection additional control devices need to be installed. Factory fitting is possible. Please contact Thermal Management.

FOR SPRINKLER SYSTEMS

Steel plate housing, wall-mounted version, equipped with mains power switch, low-voltage (LV) relay, RCD/CB combination(s), buzzer, power contactor(s), auxiliary contactor(s), operating mode selector switch, Indicators for `Operating and Fault`, `Mains power`, inlet and outlet terminals. Completely assembled, wired and inspected. Wiring schematics included in housing 1 temperature controller is installed per heating circuit in the switch cabinet.

SBS-02-SNR Control panel for 2 heating circuits (Inc. redundant).

SBS-04-SNR Control panel for 4 heating circuits (Inc. redundant).

SBS-06-SNR Control panel for 6 heating circuits (Inc. redundant).

SBS-08-SNR Control Panel for 8 heating circuits (Inc. redundant).

SBS-10-SNR Control panel for 10 heating circuits (Inc. redundant).

SBS-12-SNR Control panel for 12 heating circuits (Inc. redundant).

Cabinet type		SBS-02-SNR	SBS-04-SNR	SBS-06-SNR	SBS-08-SNR	SBS-10-SNR	SBS-12-SNR
Number of pipes		1	2	3	4	5	6
Number of heating circuits (Including redundant heating circuit)		2	4	6	8	10	12
Dimensions	Width	600	800	800	800	1000	1000
	Height	600	800	800	1000	1000	1000
	Depth	210	210	210	300	300	300
Weight	kg	45	90	90	115	140	140
Max. nominal current (InA)	Amps	32	32	32	63	63	63
Colour	RAL	7035	7035	7035	7035	7035	7035
Main isolator switch rating	Amps	32	32	32	63	63	63
Circuit breaker sizing	Amps	16	16	16	16	16	16
Short circuit current range (Icc)	kA	10	10	10	10	10	10
Controller setpoint (Primary)		+8C	+8C	+8C	+8C	+8C	+8C
Controller setpoint (Redundant)		+5C	+5C	+5C	+5C	+5C	+5C

THERMOSTATS

AT-TS-13

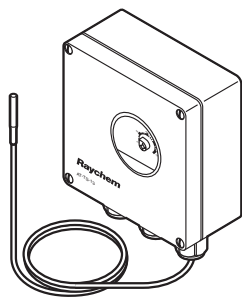

Thermostat

- Adjustable temperature range: -5°C to $+15^{\circ}\text{C}$
- Line-sensing control thermostat or ambient thermostat
- Max. switching current 16 A, 250 VAC

Note: When selecting the AT-TS-** thermostats, ensure that the maximum circuit length for a 16A circuit is not exceeded.

AT-TS-14

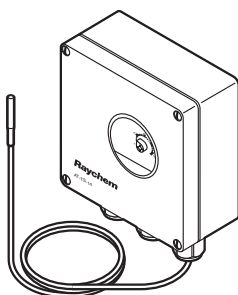

Thermostat

- Adjustable temperature range: 0°C to 120°C
- Temperature maintenance on pipelines for fatty waste water
- Line-sensing control thermostat
- Max. switching current 16 A, 250 VAC

Note: When selecting the AT-TS-** thermostats, ensure that the maximum circuit length for a 16A circuit is not exceeded.

RAYSTAT-ECO-10



Ambient temperature thermostat

- Adjustable temperature range: 0°C to 30°C
- Max. switching current 25 A, 250 VAC
- PASC (Proportional Ambient Sensing Control) for energy saving
- Alarm relay: 2 A voltfree with indication of sensor errors, voltage errors and low or high temperature alarm
- Display for visual indication of parameters

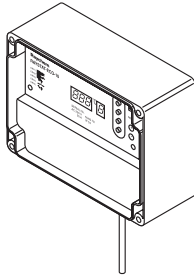

RAYSTAT-CONTROL-10

Line-sensing thermostat

- Adjustable temperature range: 0°C to 150°C
- Max. switching current 25 A, 250 VAC
- Alarm relay: 2 A voltfree with indication of sensor errors, voltage errors and low or high temperature alarm
- Display for visual indication of parameters

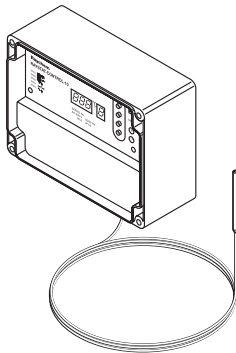

RAYSTAT-CONTROL-11-DIN

Line sensing thermostat with digital display for DIN rail mounting applications.

- Set temperature range: 0 - 65°C.
- Digital display of maintain temperature and alarm information.
- 16A switching.
- Low temperature alarm function
- DIN rail/Panel mountable control.
- Sensor type: PT100.

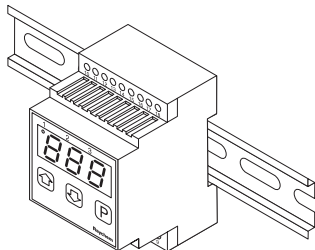

SB-100

Stainless steel support bracket

- Specially constructed to provide heating cable protection between pipe and junction box via a tubular leg.
- For use with AT-TS-13, AT-TS-14, JB16-02 and RAYSTAT-CONTROL-10

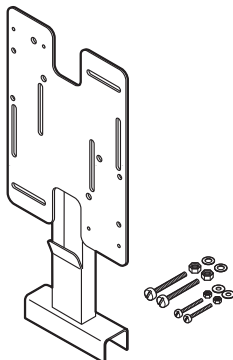

SB-101

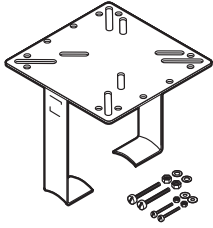

Dual-leg support bracket, stainless steel

- Height leg: 160 mm
- For use with AT-TS-13, AT-TS-14, JB16-02 and RAYSTAT-CONTROL-10

SB-110

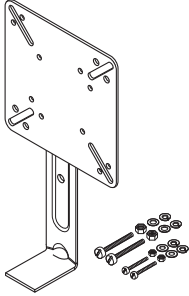

Support bracket, stainless steel

- Height leg: 100 mm
- For use with AT-TS-13, AT-TS-14, and JB16-02

SB-111

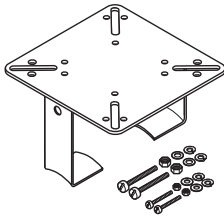

Support bracket, stainless steel

- Height leg: 100 mm
- For use with AT-TS-13, AT-TS-14, and JB16-02

ACCESSORIES

RayClic-CE-02

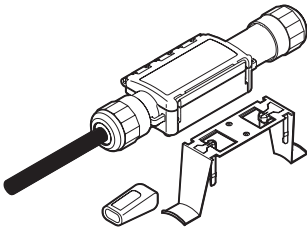

Power connection

- With 1.5 m power cable
- End seal and support bracket
- IP 68
- External dimension: L = 240 mm
W = 64 mm
H = 47 mm

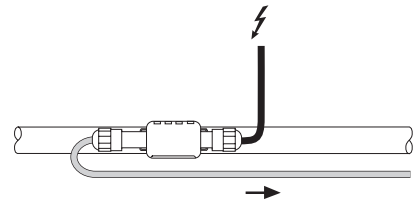

RayClic-T-02

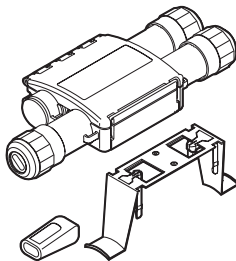

T-connection

- Connection for 3 cables
- End seal and support bracket
- IP 68
- External dimension: L = 270 mm
W = 105 mm
H = 42 mm

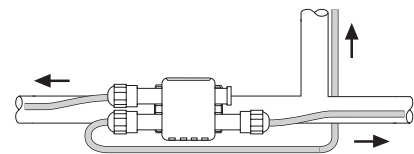

RayClic-PT-02

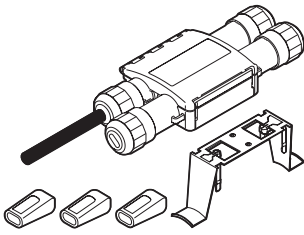

Power T-connection

- 3 connections with integral 1.5 m power cable
- 3 end seals and 1 support bracket
- IP 68
- External dimension: L = 270 mm
W = 105 mm
H = 42 mm

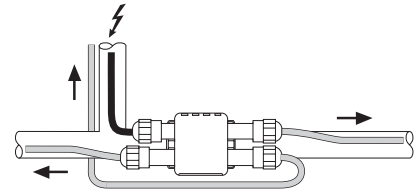

RayClic-S-02

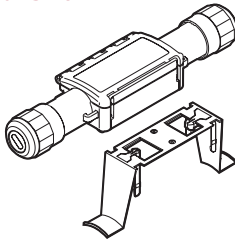

Splice for joining 2 lengths of heating cable

- Connection for 2 cables with 1 support bracket
- IP 68
- External dimension: L = 240 mm
W = 64 mm
H = 47 mm

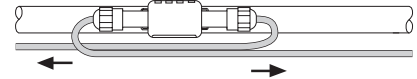

RayClic-PS-02

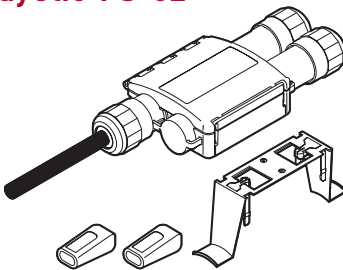

Powered splice

- Connection for 2 cables with integral 1.5 m power cable
- 2 end seals and 1 support bracket
- IP 68
- External dimension: L = 270 mm
W = 105 mm
H = 42 mm

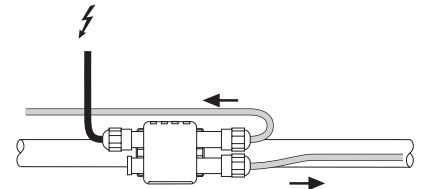

RayClic-X-02

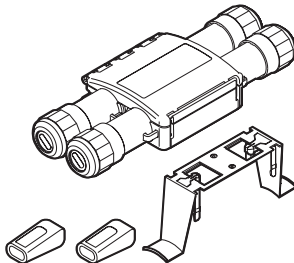

4-way connection

- Connection for 4 cables
- 2 end seals and 1 support bracket
- IP 68
- External dimension: L = 270 mm
W = 105 mm
H = 42 mm

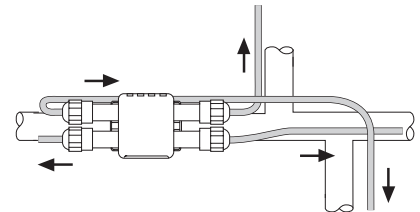

RayClic-E-02

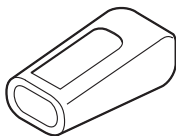

Gel-filled end seal

- For system extensions (to be ordered separately)
- IP 68

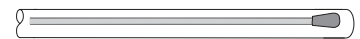

JB16-02

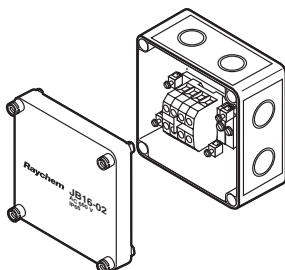

Temperature-resistant junction box

- For power connection
- IP66
- 6 x 4 mm² terminals
- 4 Pg 11/16, 4 M20/25 knock-out entries

KBL-10

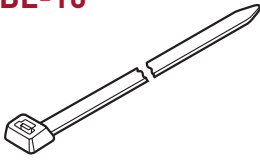

Cable ties

- One pack of 100 required for approx. 30 m of pipework
- Length: 370 mm
- Temperature and UV resistant

Use ATE-180 on plastic pipes

GT-66



Heat-resistant glass cloth tape

- For steel pipes or for any installation below 4.4°C
- 20 m roll for approx. 20 m of pipework

Use ATE-180 on plastic pipes

GS-54



Glass cloth tape for attaching heating cable to pipe

- For stainless-steel pipes or for any installation below 4.4°C
- 16 m per roll, 12 mm width

ATE-180

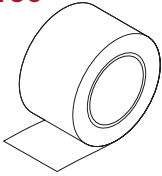

Aluminium adhesive tape

- Heat resistant
- 55 m roll for approx. 50 m of pipework

On plastic pipes: the heating cable must be covered with aluminium adhesive tape along its entire length

IEK-20-M

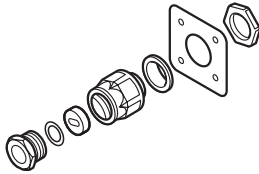

Insulation entry kit

- Insertion of heating cable in metal cladding
- Consists of: metal fastener, metric gland and joint seal

LAB-I-01



Electric traced label

- To be placed at 5 m intervals on insulation surface

SPECIAL INSTALLATION INSTRUCTIONS

PLACING OF SENSOR

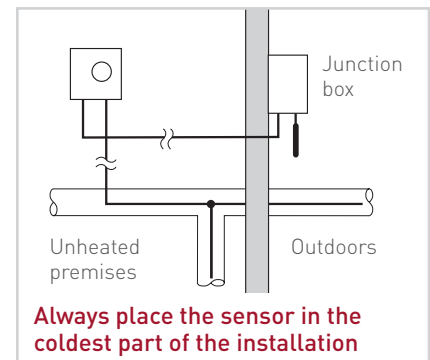
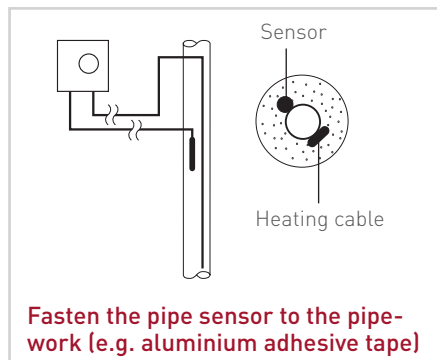
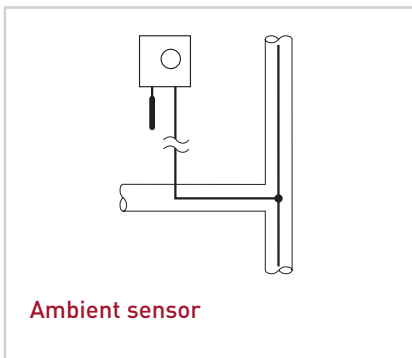

UNIT LAYOUT

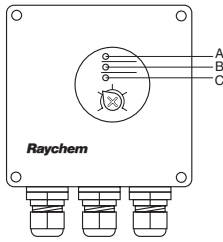

A Green LED	Heating cable on
B Red LED	Sensor break
C Red LED	Sensor short-circuit

TECHNICAL DATA

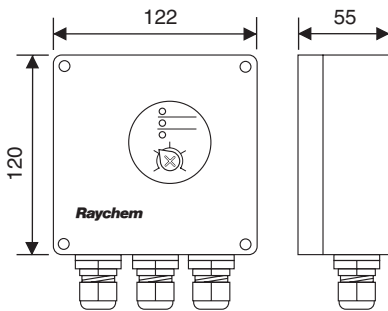

Supply voltage	230 VAC +10% -15% 50/60 Hz
Power consumption	≤ 1.8 VA
Approval	CE
Max. switching current	16 A, 250 VAC
Max. conductor size	2.5 mm ²
Switching differential	0.6 to 1 K
Switching accuracy	AT-TS-13 ±1 K at 5°C (calibration point)
	AT-TS-14 ±2 K at 60°C (calibration point)
Switch type	SPST (normally open)
Adjustable temperature range	AT-TS-13 -5°C to +15°C
	AT-TS-14 0°C to +120°C

ENCLOSURE

Temperature setting	inside
Exposure temperature	-20°C to +50°C
Ingress protection	IP65 according to EN 60529
Entries	1 x M20 for supply cable (Ø 8-13 mm) 1 x M25 for connection heating cable (Ø 11-17 mm) 1 x M16 for sensor
Weight (without sensor)	approx. 440 g
Material	ABS
Lid fixing	nickel-plated quick release screws
Mounting	On wall or on support bracket SB-110/SB-111

TEMPERATURE SENSING (HARD-69)

Type	PTC KTY 83-110
Length sensor cable	3 m
Diameter sensor cable	5.5 mm
Diameter sensor head	6.5 mm
Max. exposure temperature sensor cable	160°C

The sensor cable may be extended up to 100 m using a cable with a cross-section of 1.5 mm². The sensor cable should be shielded if it is laid in cable ducts or in the vicinity of high-voltage cables.

WIRING DIAGRAM FOR THERMOSTAT AT-TS-13 OR AT-TS-14

AT-TS-13/14 DIRECT

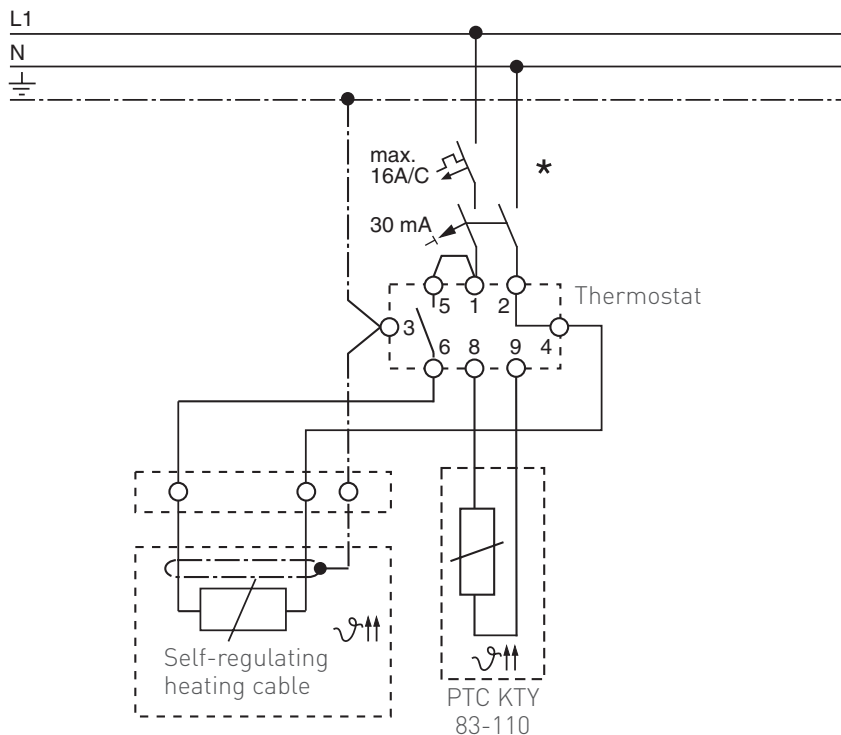
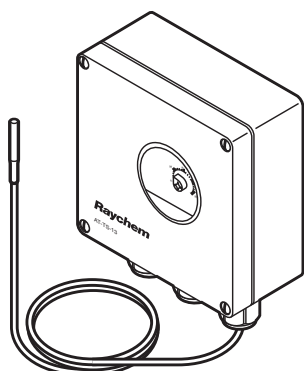

AT-TS-13/14 WITH CONTACTOR

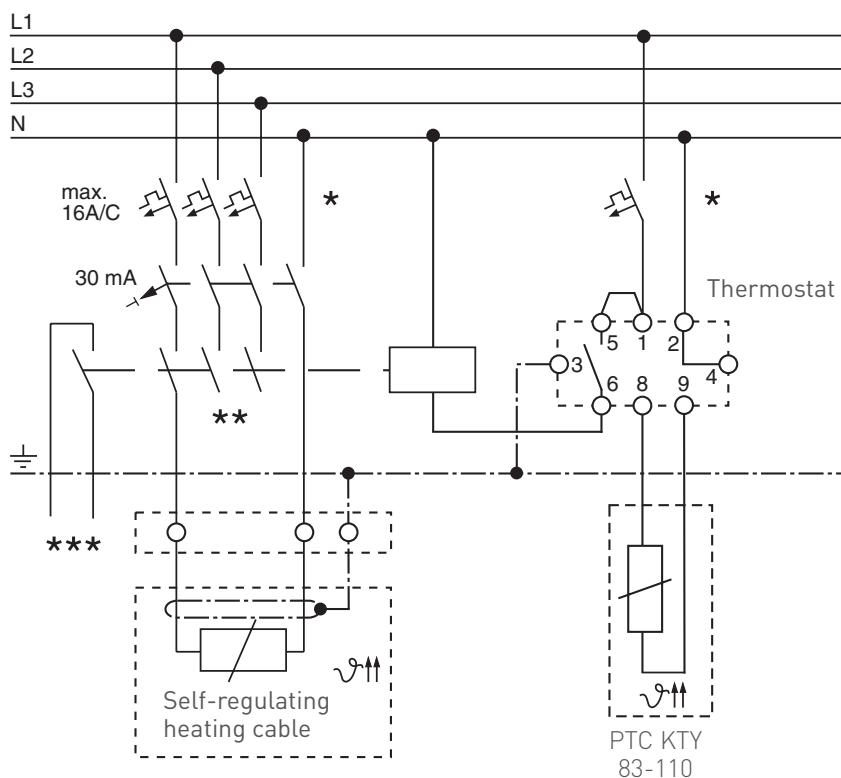

- * Two- or four-pole electrical protection by circuit-breaker may be needed for local circumstances, standards and regulations
- ** Depending on the application, one- or three-pole circuit-breakers or contactors may be used
- *** **Optional:** Potential-free circuit-breaker for connection to the BMS



DISPLAY

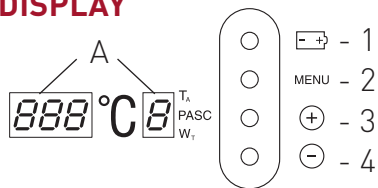

TECHNICAL DATA

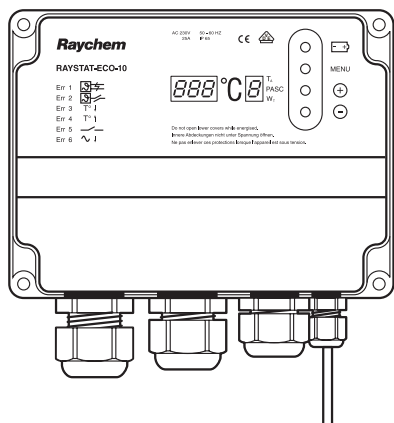

A LED Display (parameter and error indications)
1 Battery activation
2 Parameter menu selection
3 Increase value
4 Decrease value

Operating Voltage	230 VAC, +10%/-10%, 50/60 Hz
Power Consumption	≤ 14 VA
Main Relay (heating)	I _{max} 25 A, 250 VAC, SPST
Main Terminals	3 x 0.75 mm ² to 4 mm ²
Alarm Relay	I _{max} 2 A, 250 VAC, SPDT, voltfree
Alarm Terminals	(3 + ±) x 0.75 mm ² to 2.5 mm ²
Accuracy	±0.5 K at 5°C

Main parameter settings	
Energy Saving Algorithm	Proportional Ambient Sensing Control (PASC) active below setpoint
Temperature Setpoint	0°C to + 30°C (switch off temperature)
Minimum Expected Ambient	-30°C to 0°C
Temperature	(heating 10 powered)
Heater Operation if Sensor Error	ON (100%) or OFF
Voltage Free Operation	YES or NO

Energy saving with Proportional Ambient Sensing Control (PASC)

Duty cycle (power to heater on) depends on the ambient temperature. For example: If minimum temperature = -20°C and if maintain temperature (set point) = +5°C

ambient t°	% ON	
-20	100	Min. Ambient
-10	60	
0	20	Set point
3	0	

Result: At ambient temperature of -10°C, 50% energy is saved

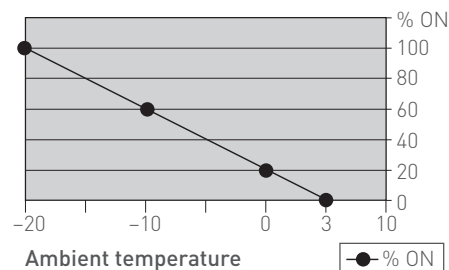

Diagnosed alarms

Sensor Errors	Sensor short / Sensor open circuit
Low Temperature	Min. expected ambient temperature reached
Voltage Errors	Low supply voltage / Output voltage / fault

Parameters can be programmed without power supply and parameters are stored in non-volatile memory.

HOUSING

Size	120 mm x 160 mm x 90 mm
Material	Grey polycarbonate
Exposure Temperature Range	-40°C to +80°C
Ingress Protection	IP 65
Entries	2 x M25, 1 x M20, 1 x M16
Weight	Approx. 800 g
Lid	Transparent with 4 captive screws
Mounting	On wall or on support bracket SB-100/SB-101

TEMPERATURE SENSOR

Sensor Type	3-wire Pt100 according to IEC Class B
Sensor Head	6 mm

Sensor cable can be extended up to 150 m when a cross-section of 3 x 1.5 mm² is used. The sensor cable should be shielded if it is laid in cable ducts or in the vicinity of high-voltage cables.



NORMAL OPERATION

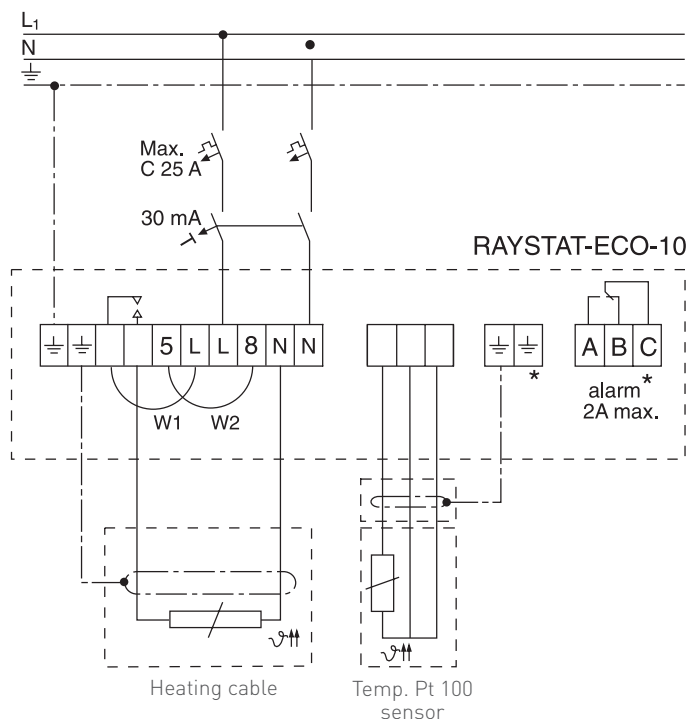
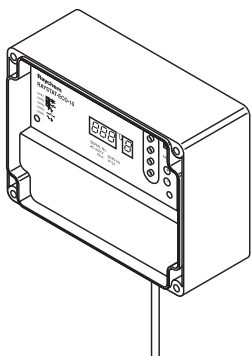

VOLTAGE FREE OPERATION: REMOVE LINKS W1 AND W2

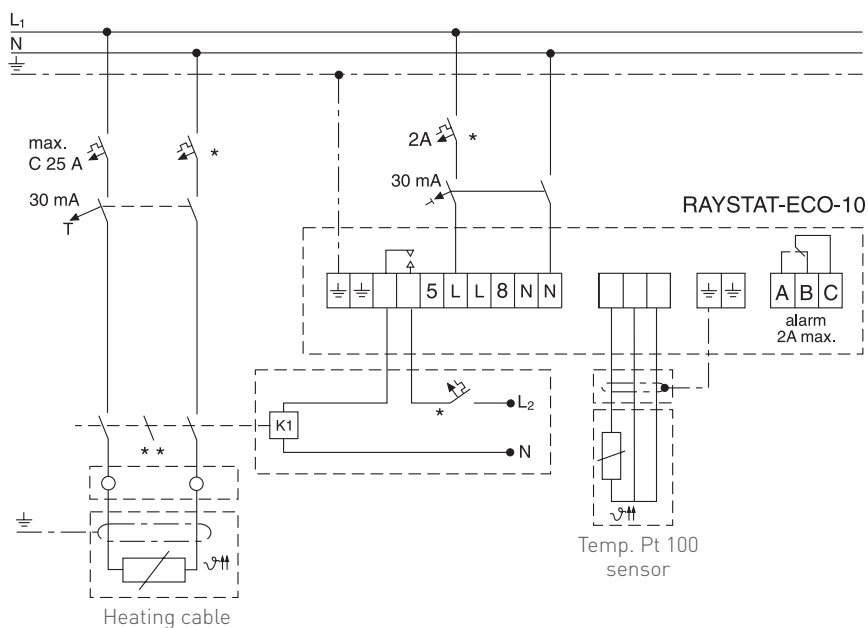

- * Electrical protection by circuit breaker may be needed for local circumstances, standards and regulations.
- ** Depending on the application, one or three-pole circuit breakers or contactors may be used.

LINE-SENSING THERMOSTAT WITH ALARM RELAY RAYSTAT-CONTROL-10

DISPLAY

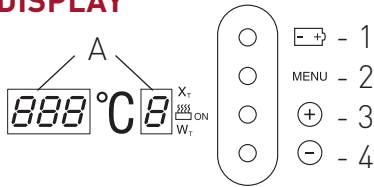

TECHNICAL DATA

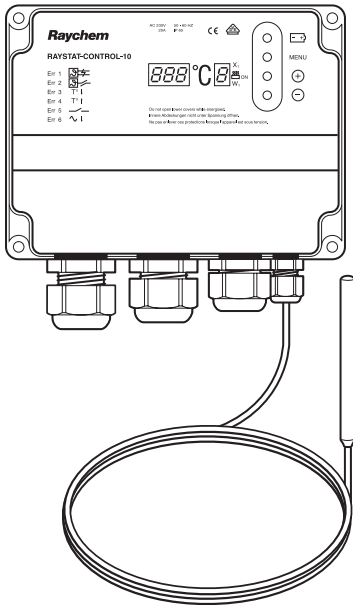

HOUSING

TEMPERATURE SENSOR

A LED Display (parameter and error indications)	
1	Battery activation
2	Parameter menu selection
3	Increase value
4	Decrease value

Operating Voltage	230 VAC, +10%/-10%, 50/60 Hz
Power Consumption	≤ 14 VA
Main Relay (heating)	I _{max} 25 A, 250 VAC, SPST
Main Terminals	3 x 0.75 mm ² to 4 mm ²
Alarm Relay	I _{max} 2 A, 250 VAC, SPDT, voltfree
Alarm Terminals	(3 + ±) x 0.75 mm ² to 2.5 mm ²
Accuracy	±0.5 K at 5°C
Ambient temperature	-40°C to +40°C

Parameter settings	
Temperature Setting	0°C to +150°C
Hysteresis	1 K to 5 K
Low Temperature Alarm	-40°C to +148°C
High Temperature Alarm	+2°C to +150°C or switched OFF
Heater Operation if Sensor Error	ON or OFF
Voltage Free Operation	YES or NO

Diagnosed errors	
Sensor Errors	Sensor short / Sensor open circuit
Temperature Extremes	High temperature / Low temperature
Voltage Errors	Low supply voltage / Output fault

Parameters can be programmed without power supply and parameters are stored in non-volatile memory.

Size	120 mm x 160 mm x 90 mm
Material	Grey polycarbonate
Ingress Protection	IP 65
Entries	2 x M25, 1 x M20, 1 x M16
Weight	Approx. 800 g
Lid	Transparent with 4 captive screws
Mounting	On wall or on support bracket SB-100/SB-101

Sensor Type	3-wire Pt100 according to IEC / Class B
Sensor Head	50 mm x Ø 6 mm
Sensor Cable Length	3 m x Ø 4 mm
Cable Exposure Temperature	-40°C to +150°C (+215°C, 1000 h max.)

Sensor cable can be extended up to 150 m when a cross-section of 3 x 1.5 mm² is used. The sensor cable should be shielded if it is laid in cable ducts or in the vicinity of high-voltage cables.

WIRING DIAGRAM FOR RAYSTAT-CONTROL-10

NORMAL OPERATION

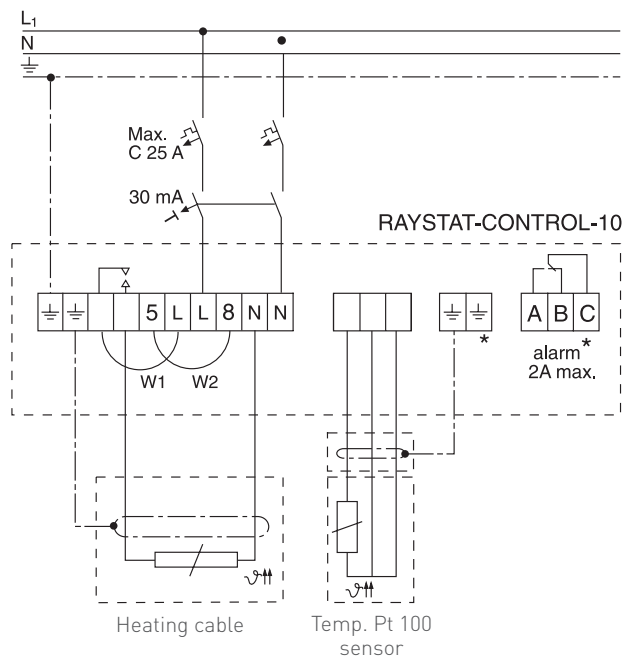
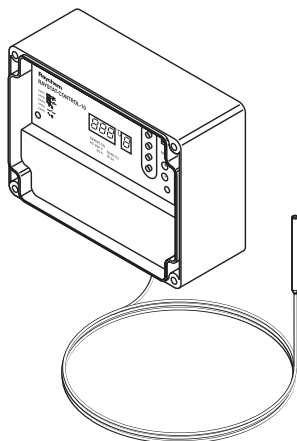

VOLTAGE FREE OPERATION: REMOVE LINKS W1 AND W2

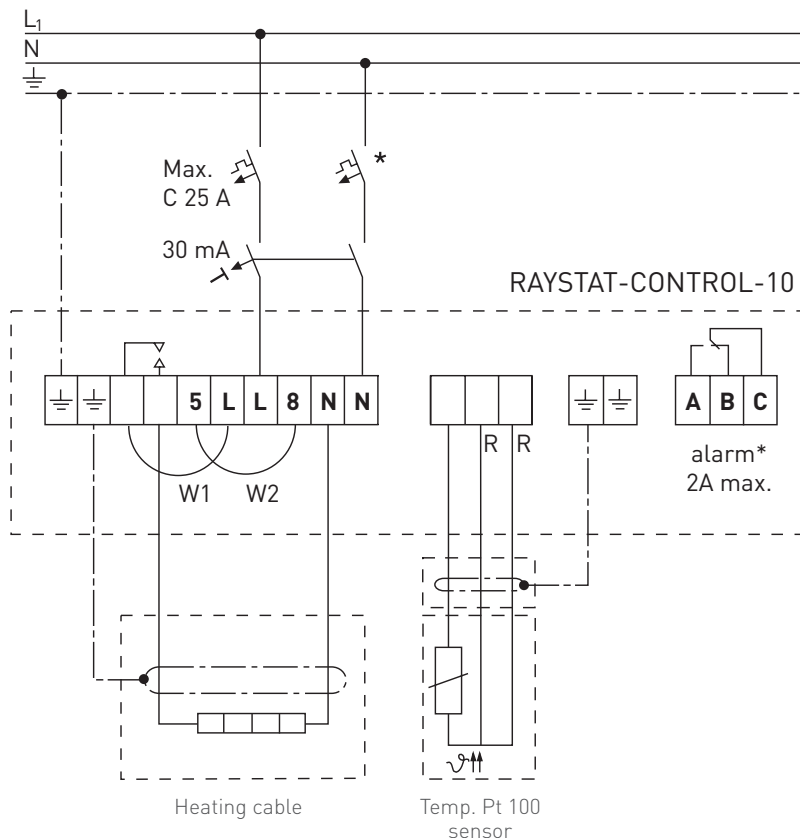

- * Electrical protection by circuit breaker may be needed for local circumstances, standards and regulations
- ** Depending on the application, one or three-pole circuit breakers or contactors may be used
- *** Optional

RAYSTAT-CONTROL-11-DIN LINE-SENSING THERMOSTAT FOR RACK MOUNTING WITH ALARM RELAY

DISPLAY

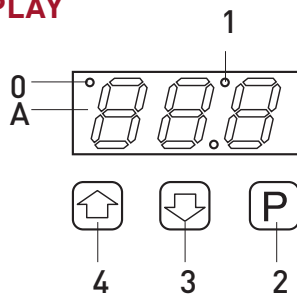

A LED display (parameter and error indications)

0 Control relay ON

1 Alarm relay activated

2 Programming button

3 Reduce value

4 Increase value

TECHNICAL DATA

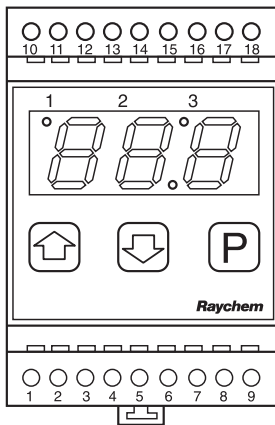

Operating voltage	230 Vac, +10%/-10%, 50/60 Hz
Power consumption	≤5 VA
Control relay (heating)	I _{max} 16 A, AC 250 V, SPST
Connecting terminals	2.5 mm ² screwed
Alarm relay	I _{max} 8 A, AC 250 V, SPDT, voltage-free
Accuracy	±1 K at 0 to 50°C
Operating temperature	-10°C to +55°C
Storage temperature	-20°C to +60°C

Programmable parameter settings		Factory setting
Temperature setting	0°C to +63°C	5°C
Hysteresis	1 K to 5 K	1 K
Low temperature alarm	-15°C to 0°C or „Off“ position.	0°C
Heater operation if sensor error	ON or OFF	ON
Voltage-free operation	YES	

HOUSING

Diagnosed errors	
Sensor error	Sensor short-circuit / Sensor open-circuit / 3-wire sensor missing
Temperature error	Low temperature

All parameters are stored in a non-volatile memory.

Dimensions	51.5 mm x 87.5 mm x 58 mm (W x H x D)
Material	Housing in ABS
Ingress protection	IP 20 (IP 30 installed in switchgear cabinet)
Mounting	DIN 35 mm rack mounting

TEMPERATURE SENSOR

Type	Pt 100 (3-wire technology) as per IEC class B
Sensor element	50 mm x Ø 6 mm stainless steel sheath
Protection rating	IP 68
Sensor cable length	3 m x Ø 5 mm
Ambient temperature	-50°C to 105°C

The sensor can be extended with a 3-wire shielded cable with max. 7.5 Ω per wire (with 3 x 1.5 mm² max. 150 m). The shielding should be earthed in the switchgear cabinet.

WIRING DIAGRAM FOR RAYSTAT-CONTROL-11-DIN

NORMAL OPERATION

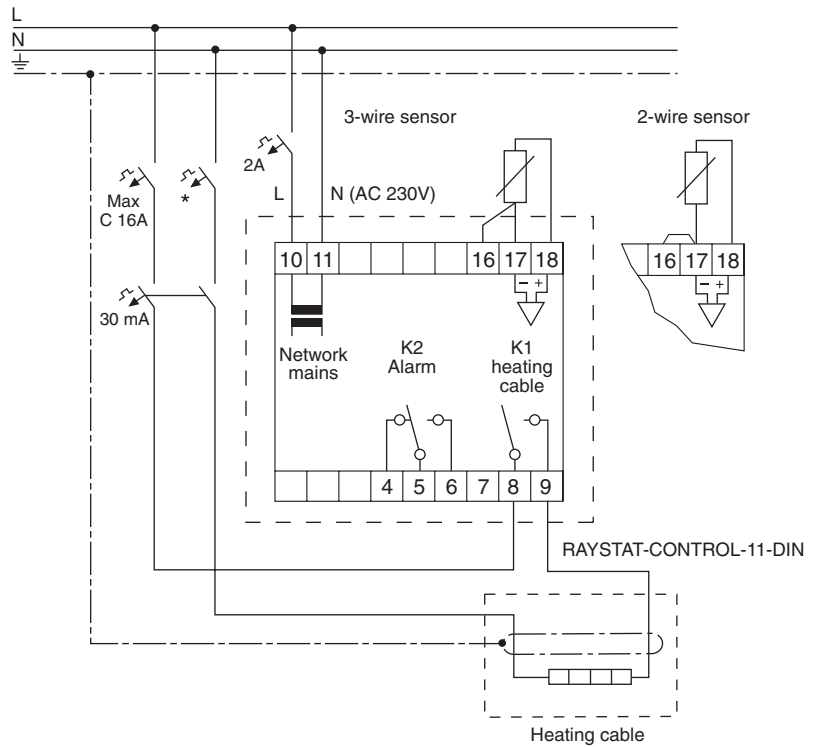
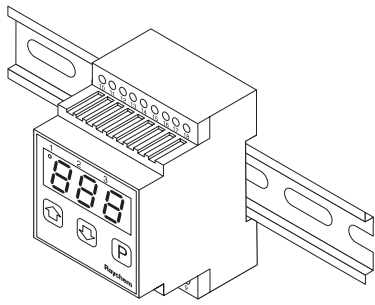

VOLTAGE-FREE OPERATION WITH POWER CONTACTOR

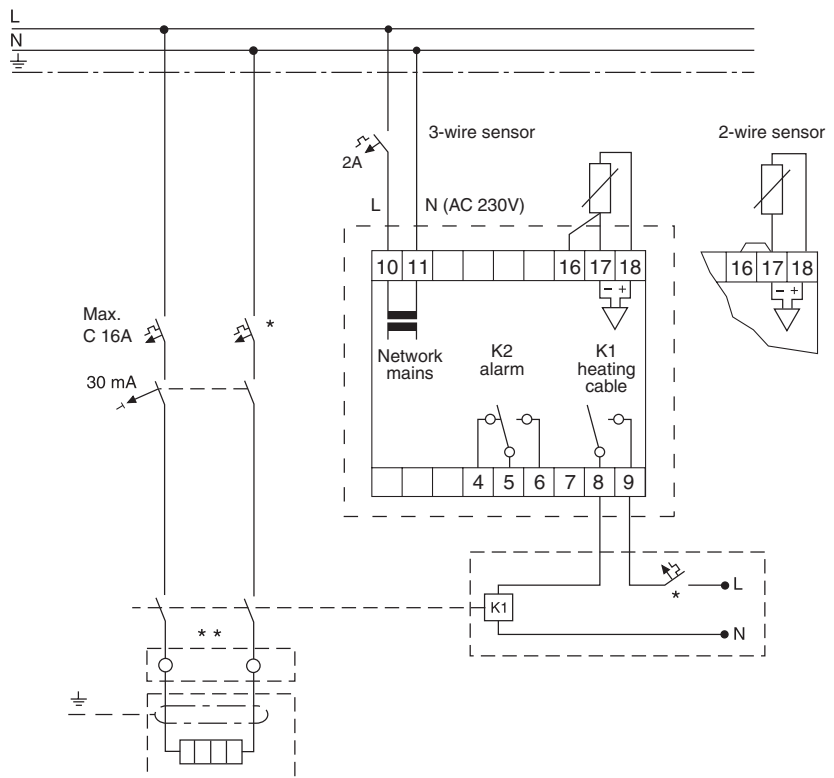

* Regional factors, standards and regulations may require two to four-pole disconnection by circuit breakers/ground fault circuit interrupters.

** Depending on the application, both single and multipole contactors are possible.

PIPE FREEZE PROTECTION

INSTALLATION INSTRUCTIONS FOR XL-TRACE LSZH CABLES

- The heating cable should be installed in a straight line on the pipework.
- Install on dry surfaces
- Minimum installation temperature: -20°C

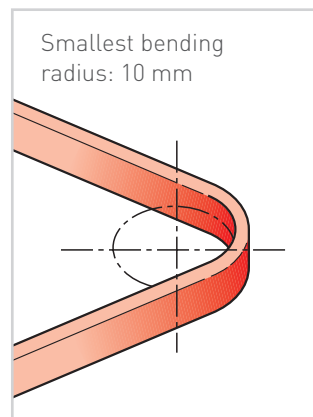
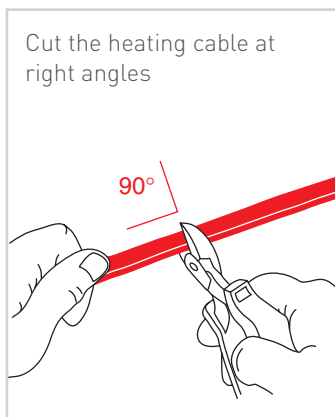
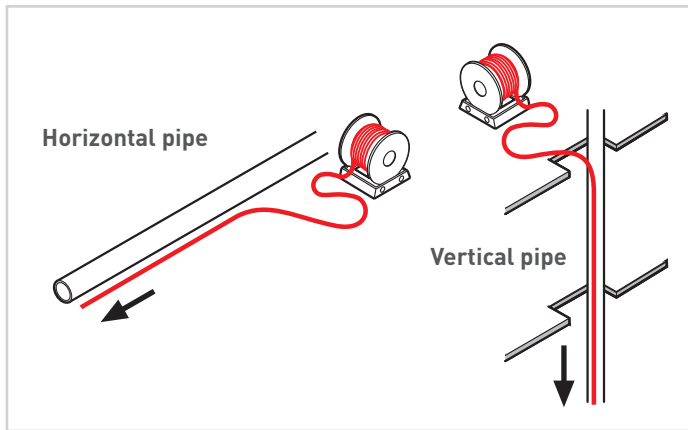

Installation of self-regulating heating cables

- Store in a dry and clean place.
- Temperature range: -40°C to $+60^{\circ}\text{C}$.
- Protect any cable ends with an end seal.

Avoid:

- sharp edges
- high tractive force
- kinking and crushing
- walking or driving over the cable
- moisture at cable interfaces

max. 300 mm

horizontal pipes

ca. 45° ca. 45°

Cable tie KBL-10

For plastic pipes use aluminium adhesive tape ATE-180. Place it over the entire length of the pipe

GT-66 / GS-54 adhesive tape

It is not necessary to spiral the cable around the pipe

Install the heating cables on the outside of the pipe bend

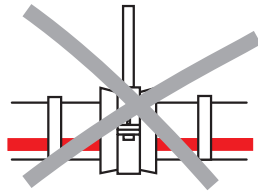
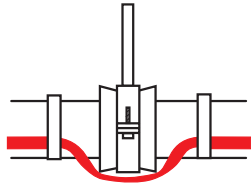

- Run the cable over pipe suspensions
- Do not clamp the cable

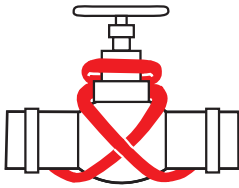
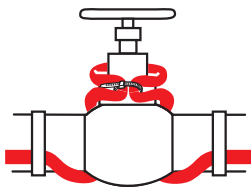

Frost protection at valves:

- Valves up to 2" (DN 50) : install the frost protection heating cables in a straight line
- $\geq 2"$: lay as shown
- Always insulate valves

Wall/Floor transit

The thickness of thermal insulation must be continuous otherwise compensate by adding heating cable.

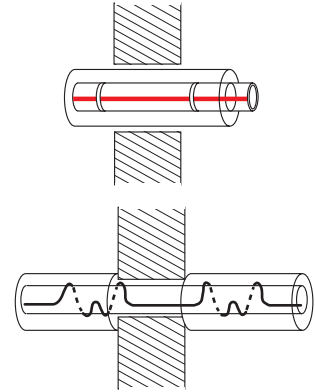

≤ 3 m

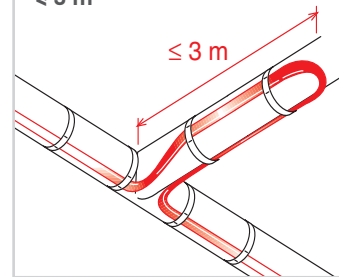

> 3 m + RayClic

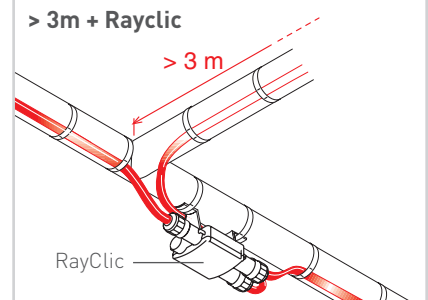

RayClic-T-connection

Electric traced label

IEK-20-M for insertion of heating cable in metal cladding

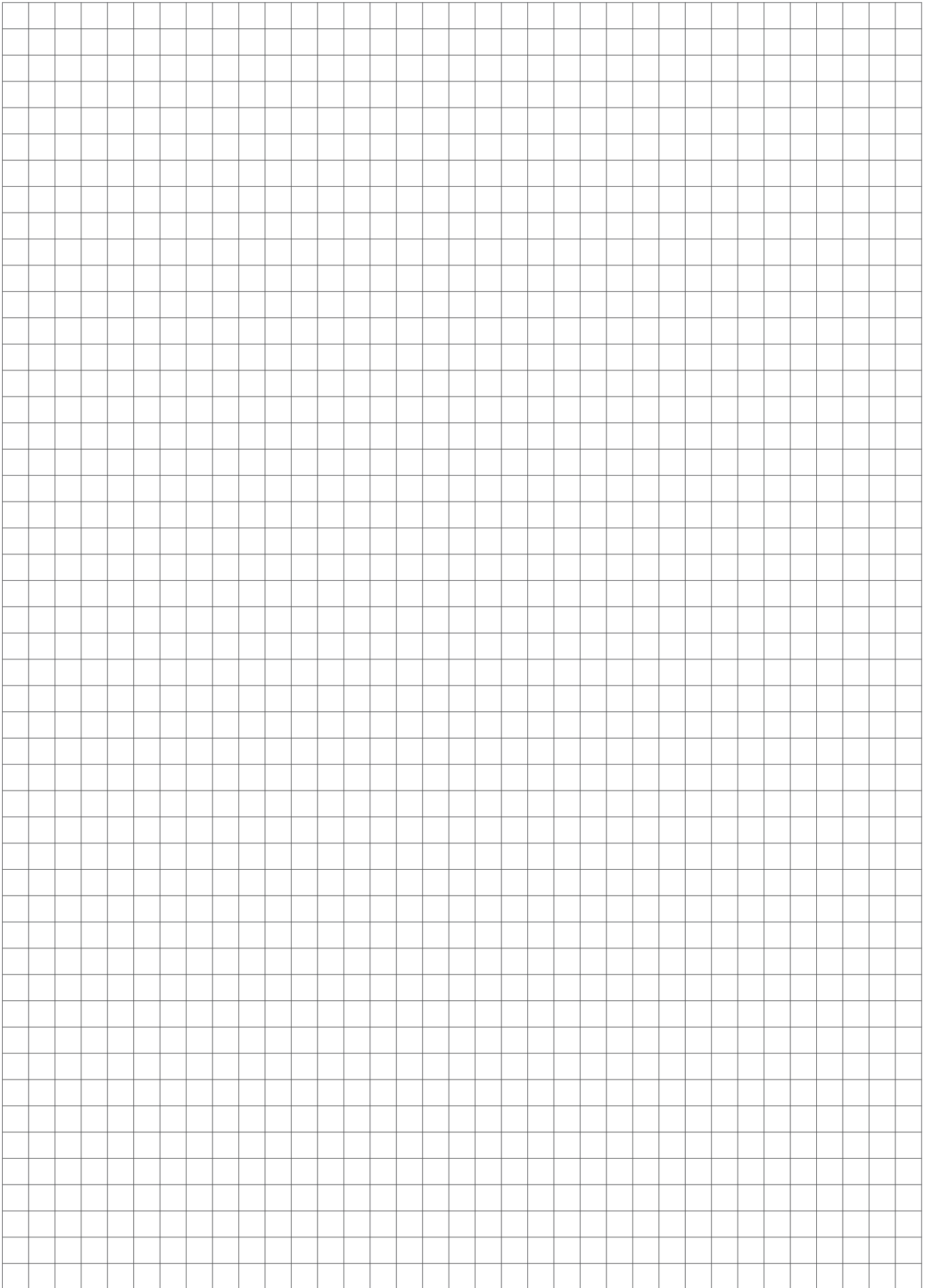

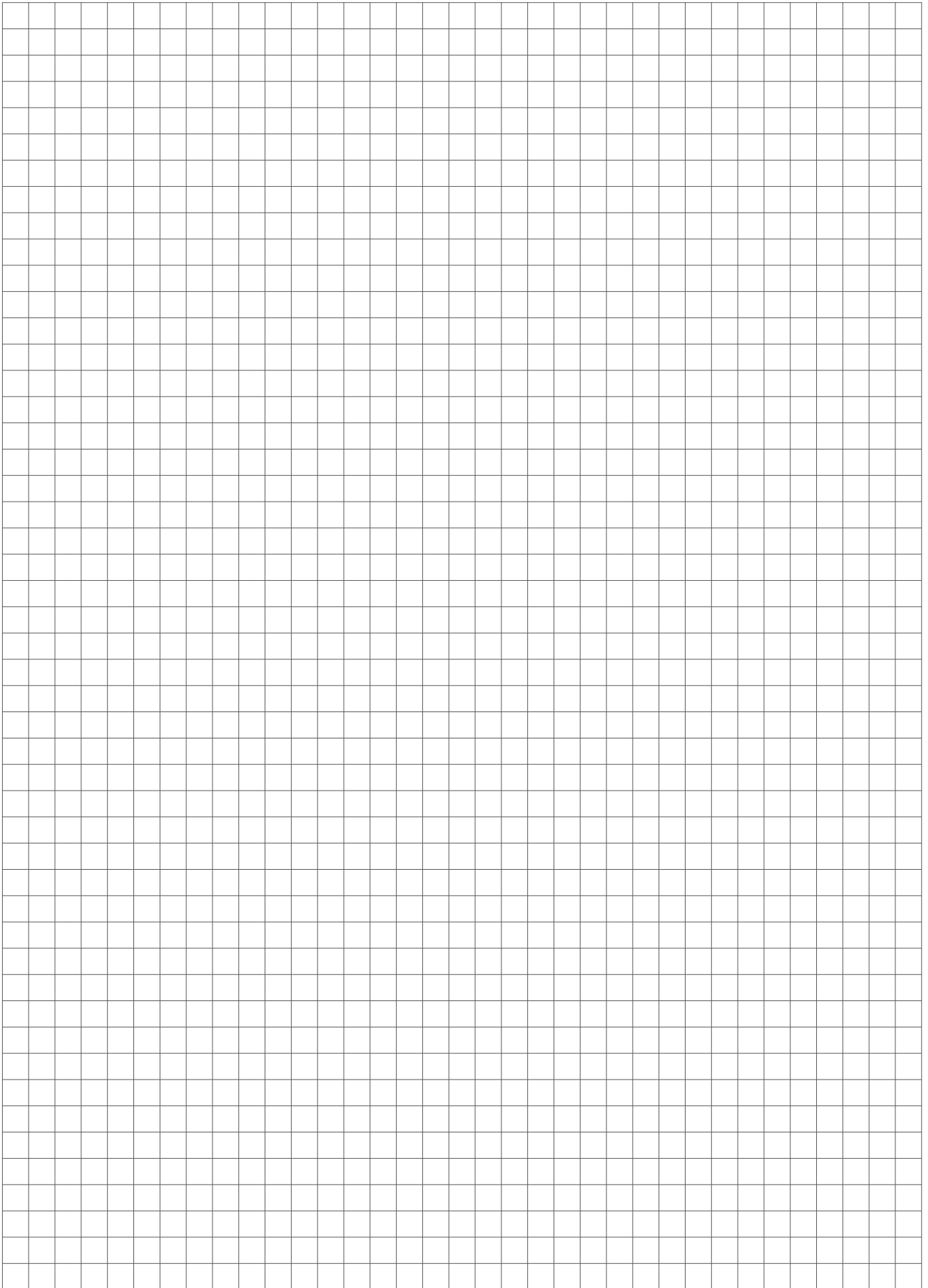



WWW.PENTAIRTHERMAL.COM

UNITED KINGDOM

Tel: 0800 969 013
Fax: 0800 968 624
salesthermaluk@pentair.com

IRELAND

Tel: 1800 654 241
Fax: 1800 654 240
salesIE@pentair.com

SOUTH EAST ASIA

Tel: +65 67685800
Fax: +65 67322263

AUSTRALIA

Tel: +61 2 97920250
Fax: +61 2 97745931
ausalesthermal@pentair.com

INDIA - NOIDA

Tel: +91 120 464 9500
Fax: +91 120 464 9548
PTMinfome@pentair.com

INDIA - MUMBAI

Tel: +91 22 6775 8800/01
Fax: +91 22 2556 1491
PTMinfome@pentair.com

UAE

Tel: +971 4 378 1700
Fax: +971 4 378 1777
PTMinfome@pentair.com

Pentair is owned by Pentair or its global affiliates. All other trademarks are the property of their respective owners. Pentair reserves the right to change specifications without prior notice.

© 2017 Pentair.

@PentairThermal